

Defender

Air shock suspension system

Patent pending #196574

Asfir's air shock suspension system was initially developed for military use. This kit was developed for armored vehicles - i.e. heavy vehicles. The civilian version was modified for use by utility companies (electricity company, water company), foresters, fire brigade etc. - knowing that vehicles used by these organizations, usually carry a heavier load than a standard vehicle.

Advantages:

- Lowers the vehicle's gravity center without interfering with the vehicle's performance.
- Creates a large dynamic force & improves the vehicle's stability
- Maintains vehicle stability and comfort when vehicle is heavily loaded or not loaded.
- Maintains the vehicle's original geometry.
- Provides significant improvement to the vehicle's abilities while using the original springs.



Front air shock kit

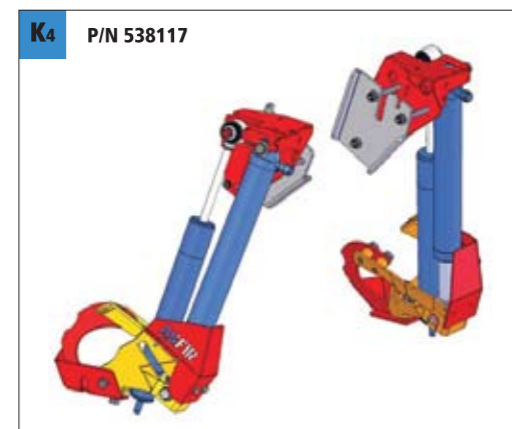

Rear air shock kit

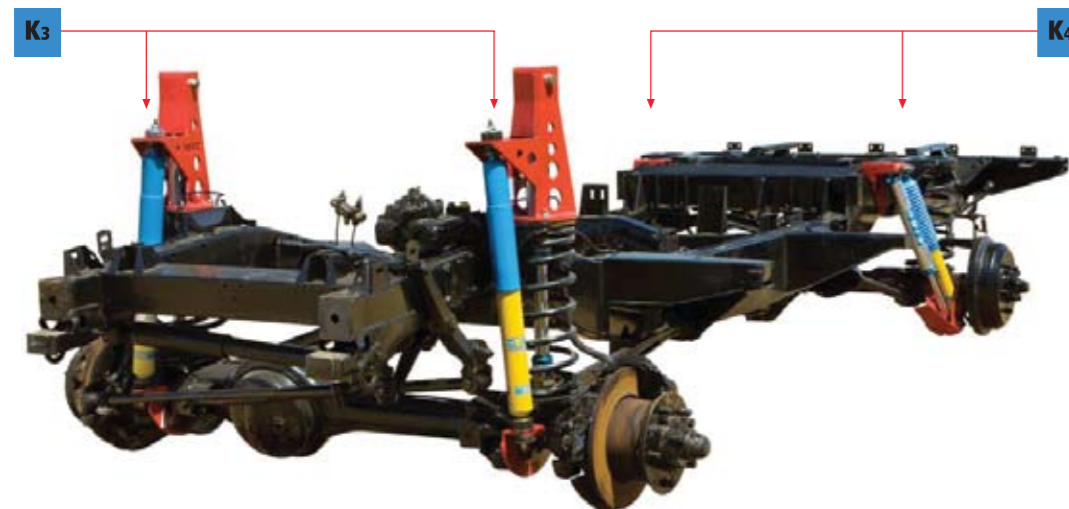

Defender

Professional Quality Products

Asfir's products are the perfect solution for accessorizing the off-road vehicle.

ATL Winch Bumper

The innovative ATL winch bumper is designed and developed to replace the original bumper. The bumper is designed for heavy duty use. ATL bumpers are characterized by their light weight and in keeping close proximity to the vehicle's original contour lines. Optional additions: Front bar, aluminum cover.

Skid Plates

Quality skid plates for off road vehicles have one of the highest design, performance and finish standards in the world. Asfir offers various skid plates protecting the underbody parts of the vehicle such as fuel tank, front axle, steering rod, rear axle and gear. The skid plates are made of quality aluminum and are screwed to original holes in the vehicle. Service openings in the skid plates enable servicing the vehicle without dismantling the plates.

Side Protectors

Protect the lower side of the vehicle and aid recovery with a jack. Designed by Asfir's Research & Development team and manufactured using the most up-to-date technology. The side protectors are made of quality metal.

4x4 Accessories

Asfir has a wide variety of accessories such as suspension seats, recovery kits, compressors, Hi Lift jacks, recovery straps, shackles, pulley blocks, ratchets and portable winch cradles.

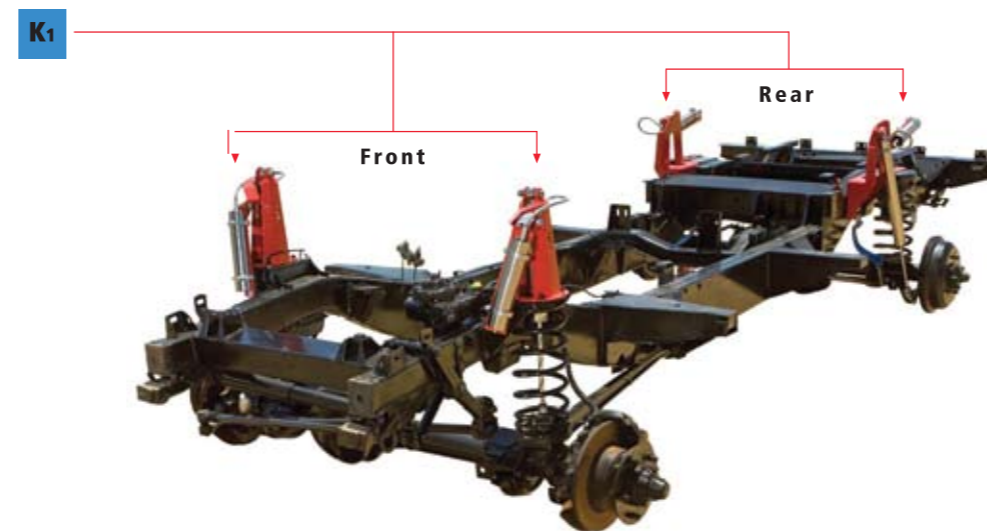

ASFIR
4x4

1.2011

QUALITY 4x4 ACCESSORIES

ASFIR LTD
Tel Adashim 19315, Israel
Telephone: +972-1599-599-499*
+972-4-6511400
Fax: +972-4-6527742
E mail: info@asfir.com
www.asfir.com
* (Israel only)



Distributed by :



Land Rover 4x4 Defender



Defender

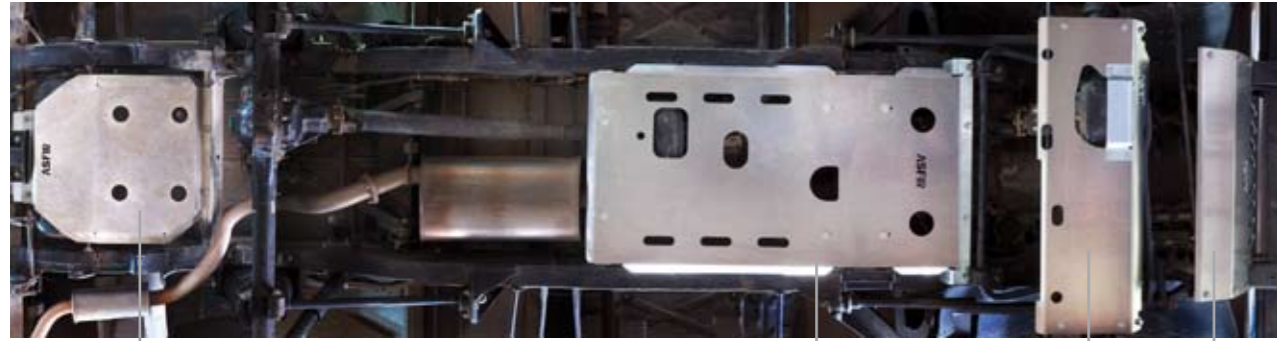

B6

B8

B4

B1

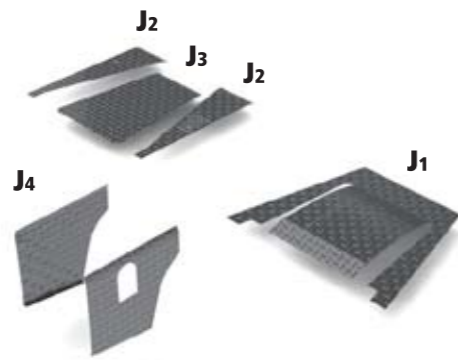
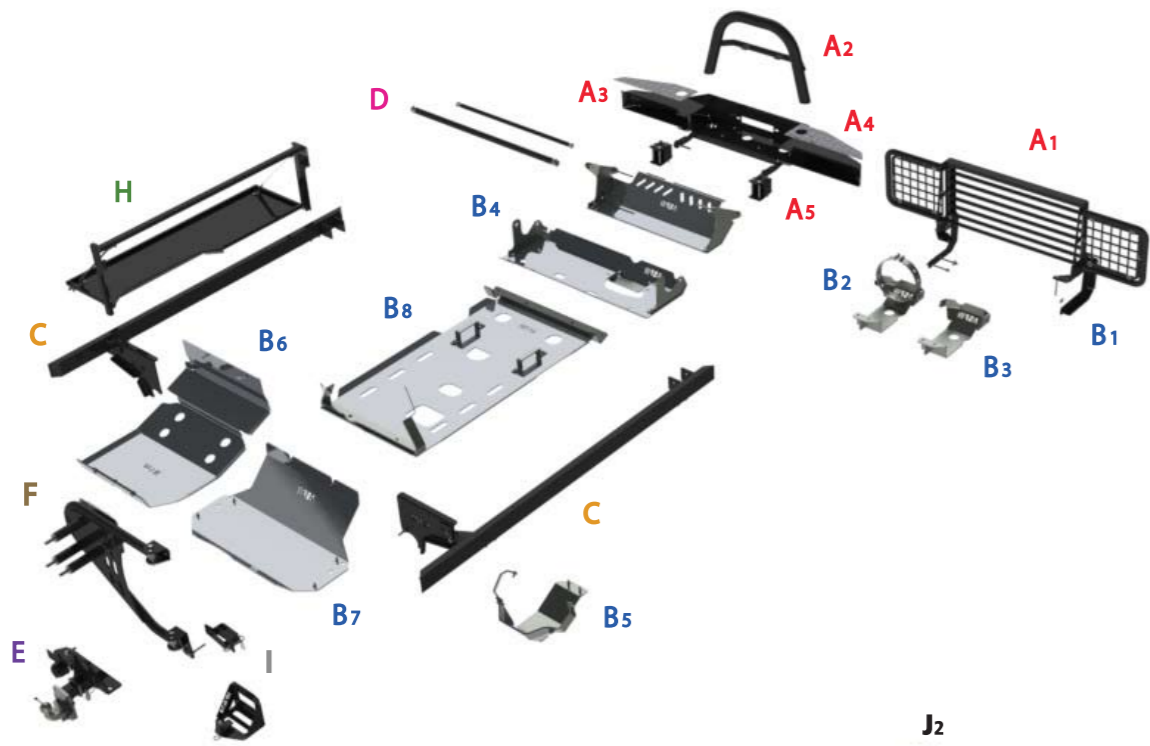

Aluminum plating

	P/N	Description	Model
J1	538112	Hood cover	TD4 90/110
J2	538119	Front wing cover(left+right)	TDI/TD5/TD4 90/110/130
J3	538102 538110	Hood cover(can't accommodate a spare wheel) Hood cover(can accommodate a spare wheel)	TDI/TD5 90/110/130 TDI/TD5 90/110/130
J4	538121 538127	Rear wing cover(left + right)	TDI/TD5/TD4 110 TDI/TD5/TD4 90



Front grill protector

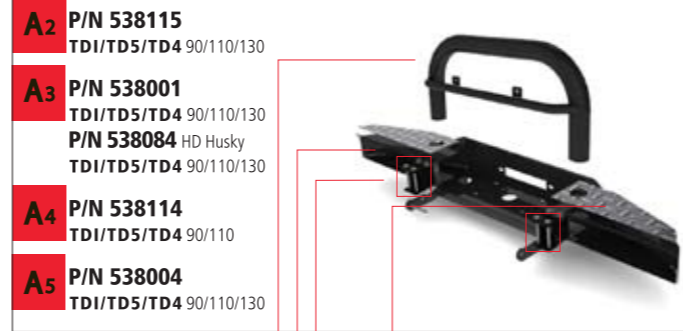

A2 Front bar for ATL bumper
A3 ATL winch bumper



B1 Steering rod skid plate
(Suitable for LH steering only)



B2 Front differential protector
(Cannot be mounted with B4)



B3 Front differential protector
with welded brackets
(Cannot be mounted with B4)



B4 Front axle skid plate
(Cannot be mounted with B2 & B3)



B5 Rear differential protector



B6 Fuel tank skid plate



B7 Fuel tank skid plate



B8 Transmission (Gear) skid plate



C Side protectors



D a. Steering rod
b. Steering tie rod



E Detachable tow bar



F Spare wheel carrier (hard top only)
(Cannot be mounted on vehicles with
central electric locking system)



H Side shelf



I Hi Lift Jack carrier

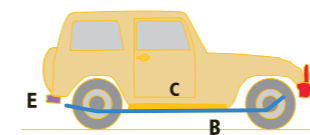

Off road kit:

Asfir's off road system was initially developed for military use. The idea was to improve the stability and traversability of vehicles carrying heavy loads and driving on rough off road terrain. The civilian kit was modified for use by the average off roader, seeking extra stability and a better ride. Asfir's off road suspension system is standardized to fit a vehicle that is equipped with:

- 16 mm front spring - Land Rover original.
- 19.6 mm rear spring - Land Rover original.
- Front axle weight 1100 kg's - 1700 kg's
- Rear axle weight 1100 kg's - 1300 kg's
- Tires - 750/16
- Wheels - Land Rover original.

The kit can be calibrated by Asfir to fit vehicles with different weights, tires, wheels and springs.

Advantages:

- Expands the suspension stroke.
- Extends the vehicle's traversability.
- Provides the vehicle with more flexibility and prevents torsion of the chassis during harsh off road conditions.
- Improves the vehicle's braking abilities at all speeds.
- Can be ordered to fit any spring that is mounted on the vehicle.
- Maintains the vehicle's original geometry.
- Does not require any changes to be made to the vehicle.
- Utilizes the full stroke of the shock absorber - 10" front shock absorber & 14" rear shock absorber (as opposed to 8" on the original front and rear shock absorber).
- Does not interfere with the vehicle's original top travel (minimal distance of the axle from the body).

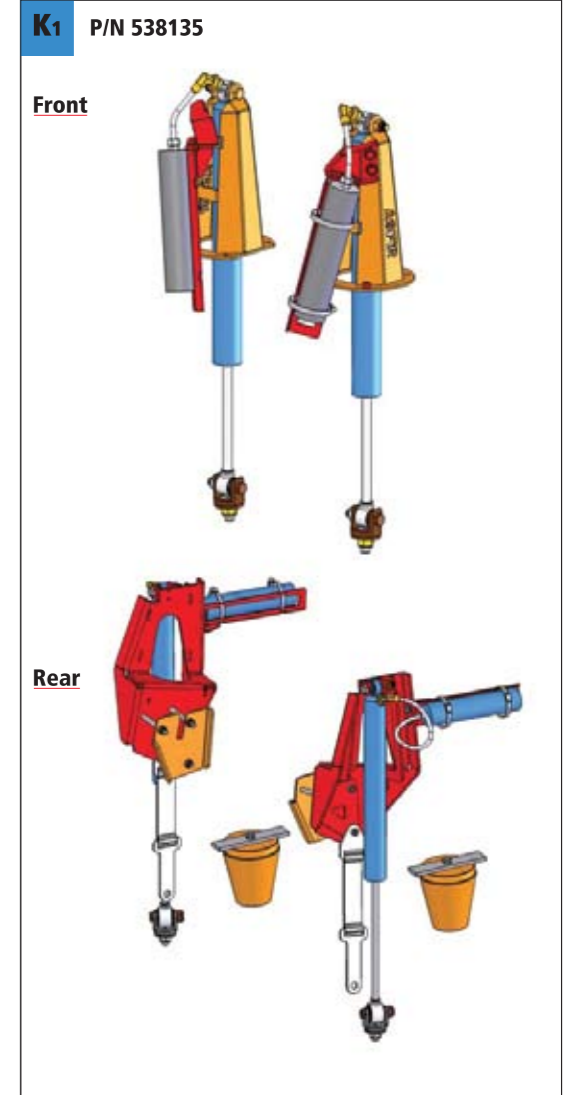

Off road suspension kit

Bump Stop Kit:

The hydraulic bump stop kit was developed to improve the passengers' driving comfort.

When the suspension stroke is in its closed position, the axle reaches the bump stop. The hydraulic bump stop suspends and prevents the passengers from feeling bumps in the driving compartment.

The bump stop's 3" stroke, assists the vehicle's suspension system at the end of the stroke, and enables better shock absorbance, movement, flexibility and driving comfort.



Front bump stop kit